



SLXD4+ SLXD4D+

Wireless System

Manual for the SLXD4+ wireless system. Contains how-to information, setup instructions, specifications and more.
Version: 1.1 (2026-B)

Table of Contents

SLXD4+ SLXD4D+ Wireless System	4	Coordination and Management Tools	24
Overview	4	Using Wireless Workbench with SLX-D+	24
Features	4	Connecting to an External Control System	24
Compatible Shure Devices	4	Firmware	25
In This Guide	4	Updating Receiver Firmware	25
Additional Resources	5	Updating Transmitter Firmware	25
SLXD4+ and SLXD4D+ Receiver	5	Rack Mounting the Receiver	26
SLXD4+ and SLXD4D+ Menu	6	Installing Footpads	27
SLX-D+ Transmitters	7	Optional Accessories	27
SLX-D+ Transmitter Menu	9	Specifications	31
Setting the Transmitter RF Power	10	Receiver Output Connectors	40
How to Use SLX-D Transmitters with SLX-D+ Receivers 10		Transmitter Input	40
Batteries and Chargers	11	Frequency Range and Transmitter Output Power	41
Battery Types	11	Frequencies for European Countries	41
SB903 Battery Chargers	12	Safety and Regulatory Information for Wireless Products	42
Average Charging Times	14	Explanation of Symbols	42
How to Set Up Your SLX-D+ System	15	Important Safety Instructions	42
Step 1: Set Up SLXD4+ or SLXD4D+ Hardware	15	Safety and Regulatory Information for Battery Chargers 43	
Step 2: Network Multiple Receivers	18	Safety Information for Batteries	43
Step 3: Link Transmitters and Receivers	19	Storing Batteries	44
Step 4: Coordinate Frequencies	20	Important Product Regulatory Information	44
Device Management	21	Regulatory Information for Class B EMC Products	44
Gain Adjustment	21	Regulatory Information for Wireless Products	46
Locking and Unlocking Devices	22	Environmental Regulatory Information	49
Audio Summing	22	Battery Regulatory Information	50
Interference Management	23	Certifications	50
Digital Feedback Reduction (DFR)	23		
Audio Encryption	24		

Regulatory Model Number (RMN)	50	Energy Efficiency	51
FCC / IC ID	51		

SLXD4+ SLXD4D+ Wireless System

Overview

SLX-D+ delivers streamlined, automated management that adjusts to confidently handle live performance, installation, location sound, and rental provider needs.

SLXD4+ and SLXD4D+ receivers feature patented digital feedback reduction software and secure audio encryption. With ShowLink® Ease, transmitter parameters can be adjusted remotely from the linked receiver without needing to resync devices. Manage multiple-system group scans and firmware updates with third-party setup and control via Ethernet.

Receivers operate over 138 MHz wideband range, or 44 MHz when used with legacy SLX-D transmitters. Transmitters run up to 8 hours using 2 AA batteries, or add Shure SB903 rechargeable batteries and charger accessories. SLX-D+ provides >118 dB dynamic range and stable, efficient RF transmission for a selection of handheld, lavalier, and headset microphones.

Features

- Transparent 24-bit digital audio
- >118 dB dynamic range
- 138 MHz wideband range (region dependent)
- Monitor and control receiver and transmitter parameters with Wireless Workbench® desktop, or remotely with the Wireless Workbench Mobile app
- Third-party setup and control via Ethernet
- Remote control and management of transmitters linked to receivers via ShowLink Ease
- Patented Shure digital feedback reduction (DFR) software
- AES-256 encryption
- Audio summing available on dual receivers

Compatible Shure Devices

Your wireless system is available in multiple configurations of transmitters, receivers, and microphones to meet your specific needs. For a full list of compatible devices you can use with your SLX-D+ system, [visit shure.com](https://www.shure.com) or contact your local sales representative.

In This Guide

This guide contains how-to instructions and specifications for the following SLX-D+ wireless system devices:

- **SLXD4+ and SLXD4D+ Receivers***
- **SLX-D+ Transmitters**:** SLXD1+ Bodypack Transmitter, SLXD2+ Handheld Transmitter, SLXD3+ Plug-On Transmitter
- **Power Sources:** SB903 Rechargeable Li-Ion Battery
- **Chargers:** SBC10-903 Single-Bay Charger, SBC203 Dual-Bay Charger, SBC80-903 Cradle Charger

*Both receiver models share the same feature set and functionality, but differ in the number of channels available and the number of audio outputs. The descriptions and procedures in this guide are applicable to the single and the dual receiver.

**SLX-D+ is also compatible with legacy SLX-D transmitters. See [How to Use SLX-D Transmitters with SLX-D+ Receivers](#) for more information.

Additional Resources

- [SLX-D+ how-to videos](#)
- [SLXD4Q+ user guide](#)
- [SLXD5+ user guide](#)
- [Legacy SLX-D user guide](#)
- [Wireless Workbench Mobile user guide](#)

SLXD4+ and SLXD4D+ Receiver

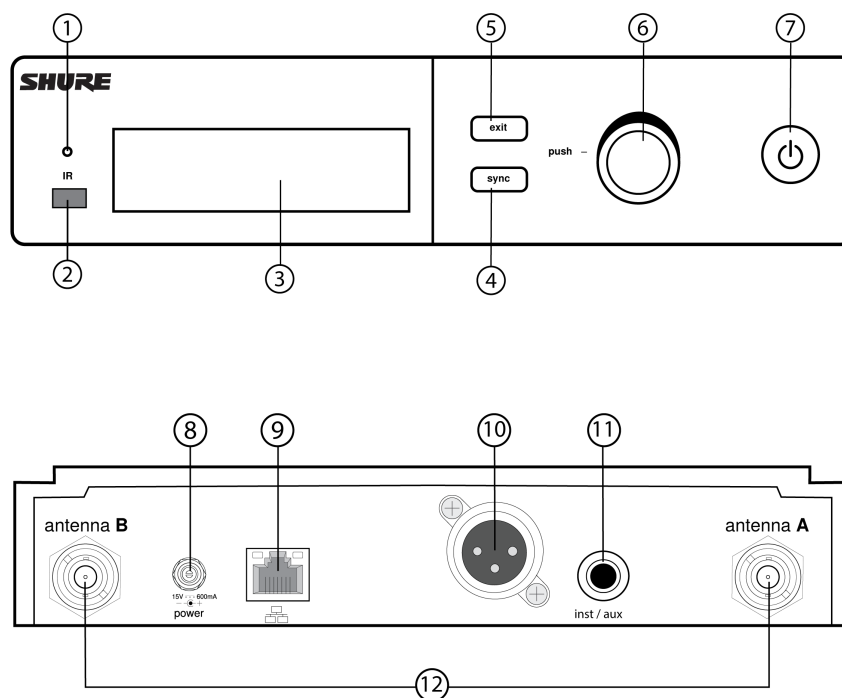

1. Sync LED:

- Flashing: IR sync mode is enabled
- Solid: Receiver and transmitter aligned for IR sync

2. **IR port:** Align with the transmitter IR port during an IR sync to program transmitters.

3. **Display:** Shows menu options, receiver settings, and transmitter settings.

4. **Sync button:** Press to activate IR sync.

5. **Exit button:** Press to cancel and exit the current operation.

6. **Control knob:** Change menu parameters. Push knob to confirm changes.

7. **Power button:** Powers receiver on or off.

8. **Power supply port:** Connection point for DC power supply.

9. **Ethernet port:** For network connection.

- Amber LED (network speed):

off = 10 Mbps, on = 100 Mbps

- Green LED (network status):

off = no network link, on = network link active

flashing = rate corresponds to traffic volume

10. **XLR audio output***: Balanced (1: ground, 2: audio +, 3: audio -)
11. **1/4" instrument/auxiliary output***: Impedance Balanced (Tip: audio+, Ring: audio-, Sleeve: ground)
12. **Antenna connectors**: BNC connector for receiver antennas.

*SLXD4D+ has an additional output

SLXD4+ and SLXD4D+ Accessories

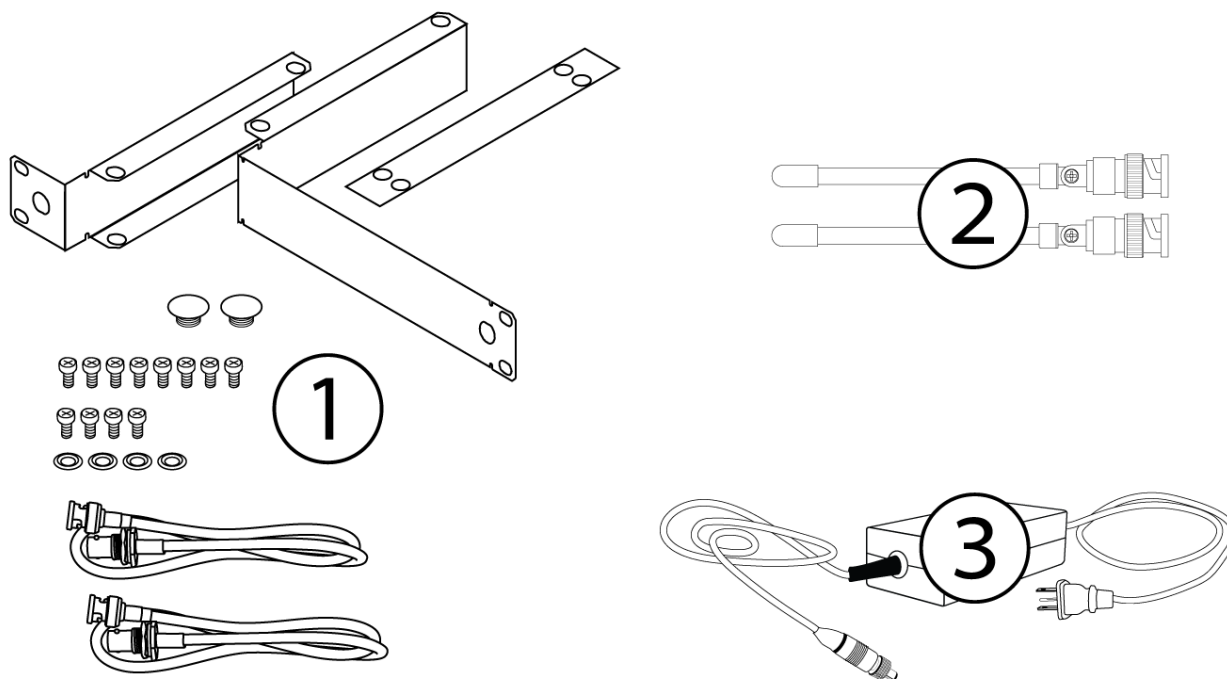

1. Rack mounting hardware
2. 1/4-wave antennas (2)
3. Power supply

SLXD4+ and SLXD4D+ Menu

The receiver has individual menu screens for setup and configuration. Push the control knob to access the menu, and rotate to advance to the next menu screen. SLXD4+ and SLXD4D+ have the following menu screens:

- **Frequency Setup**
 - **Initialize My System**: After networking receivers, coordinate your new system with step-by-step instructions on the display.
 - **Add Receiver to My System**: After networking receivers, coordinate the addition of a new receiver to your existing system with step-by-step instructions on the display.
 - **Single Channel Scan**: Receiver scans for available channels within the selected group.
 - **Manual Frequency Setup**: Manually tune the receiver to a desired frequency.
- **Channel Name**: Customize the channel name.
- **Audio Settings**
 - **Gain**: Monitor audio levels and adjust the receiver gain.
 - **Mic/Line Level**: Switch between output levels.
 - **Feedback Reduction**: Enable feedback reduction per channel to detect feedback and deploy filters that reduce feedback frequencies. See [Digital Feedback Reduction \(DFR\)](#) for more information.

- **Transmitter**
 - **Tx Remote Control:** Identify linked transmitter by flashing transmitter LEDs and edit transmitter properties in real time.
 - **Unlink:** Unlink the transmitter from a receiver channel.
 - **Add Second Tx Link:** Add another transmitter to a receiver channel that already has a linked transmitter. This menu screen only appears when a powered-off transmitter is already linked to a receiver channel. See [Linking Two Transmitters to a Receiver](#) for more information.
 - **Transmitter Firmware:** Update transmitter firmware using IR sync or ShowLink Ease.
 - **Transmitter Preset:** Change transmitter presets and apply after IR sync.
 - **Tx Factory Reset:** Reboot the transmitter and restore all settings to factory default.
 - **Device Configuration**
 - **Audio**
 - Audio Encryption:** Enable audio encryption to ensure secure audio transmission between transmitters and receivers. See [Audio Encryption](#) for more information.
 - Audio Summing:** Choose an audio summing mode.
 - **RF**
 - Interference Management:** Set the interference management mode to determine how the receiver responds to interference. See [Interference Management](#) for more information.
 - RF Band:** Change the receiver band to match your legacy narrowband transmitter band.
 - **Device Settings**
 - Device Lock:** Set receiver lock status.
 - Home Page View:** Select a home screen display.
 - Device Preset:** Save current receiver settings or restore last saved settings.
 - Controller Access:** Block (default) or allow third-party control access.
 - **Connectivity**
 - App Connection:** Enable app control, enter pairing mode, and view connected mobile devices. See [Using Wireless Workbench with SLX-D+](#) for more information.
 - Network Setup:** Switch between automatic and manual IP addressing.
 - **Factory Reset:** Restore all settings to factory default following a system reboot.
 - **About:** Displays firmware version and serial number.
 - **Help:** Provides a QR code link to additional materials.
-

SLX-D+ Transmitters

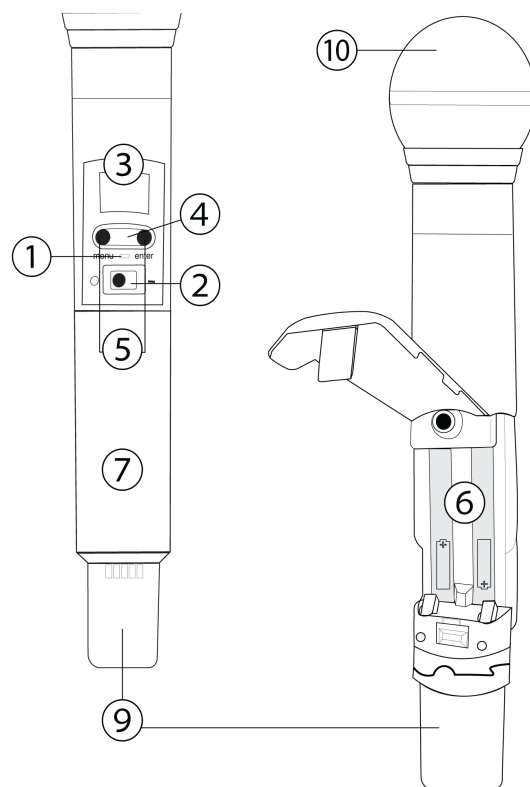
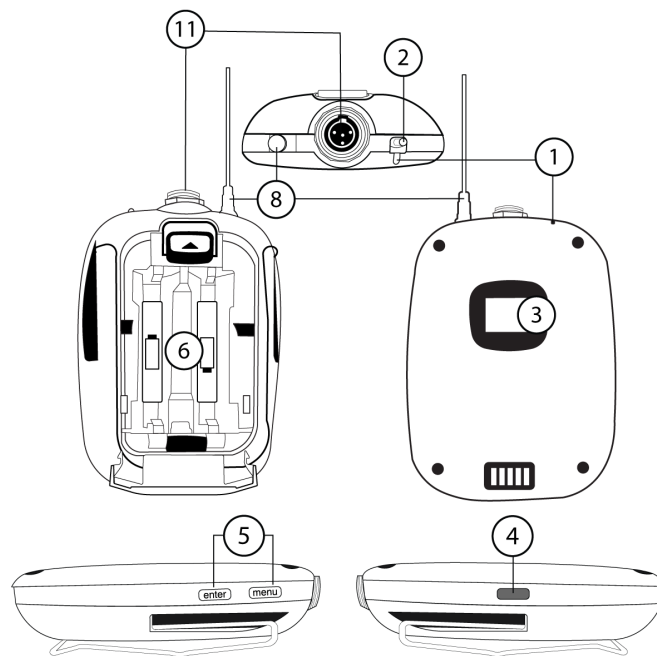

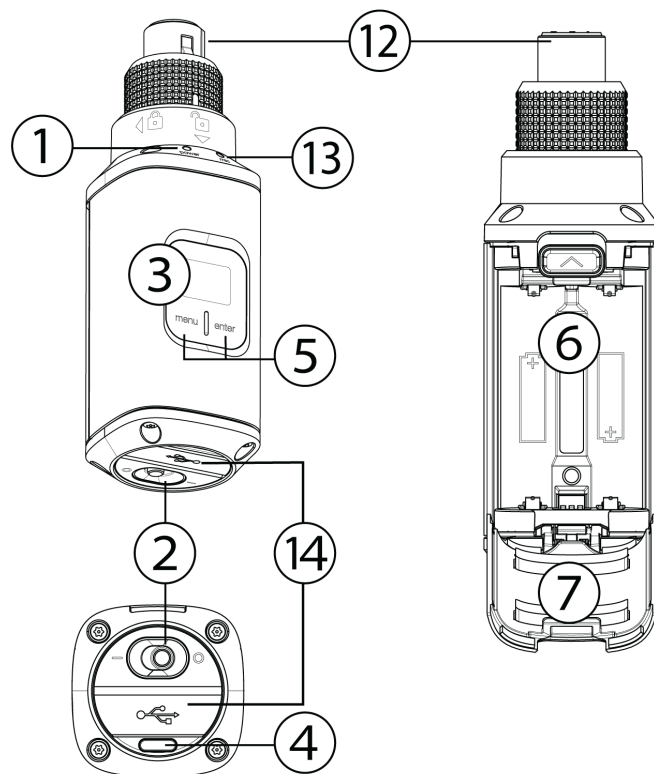

1. **Power LED:**
 - Green = Unit is powered on
 - Red = Low battery
2. **On/off switch:** Powers the transmitter on or off.
3. **Display:** View menu screens and settings. Press any control button to activate the display.
4. **IR port:** Align with a receiver IR port to link devices.
5. **Menu navigation buttons:**
 - menu = Navigate between menu screens
 - enter = Confirm and save parameter changes
6. **Battery compartment:** Requires 2 AA batteries or a Shure SB903 rechargeable battery.
7. **Battery cover:** Protects battery compartment during use.
8. **Bodypack antenna:** For RF signal transmission.
9. **Handheld integrated antenna:** For RF signal transmission.
10. **Microphone cartridge:** Interchangeable with a variety of Shure cartridges.
11. **TA4M input port:** Connects to a 4-Pin Mini Connector (TA4F) microphone or instrument cable.
12. **Locking XLR connector:** Connection point for wired microphones, cables, boom poles, and more. To release the XLR connector, turn the ring counterclockwise and push in.
13. **Microphone LED:** Indicates audio input from connected microphone, regardless of receiver status.
14. **USB-C port:** Connect USB-C cable to power on or charge transmitter.

SLX-D+ Transmitter Menu

Transmitters have individual menu screens for setting up and adjusting the transmitter. To access the menu options from the home screen, press the menu button. Each additional press of the menu button advances to the next menu screen. Use the enter button to select and confirm options on the active menu screen.

SLX-D+ transmitters have the following menu screens:

- **Home Screen:** Use the enter button to select a home screen display.

- **Mic Offset:** Match audio levels between two transmitters used in a combo system. Range is 0 to 21 dB (3 dB increments).
- **RF Power:** Select an RF power setting. See [Setting the Transmitter RF Power](#) for more information.
- **High Pass:** Turn the high pass filter on or off.
- **Battery:** To ensure accurate battery metering, set the battery type to match the installed AA battery type. This menu is not selectable when Shure rechargeable batteries are installed.
- **Lock Type:** Determine auto lock behavior. See [Locking and Unlocking Devices](#) for more information.
- **Auto Lock:** Turn the transmitter auto lock on or off. See [Locking and Unlocking Devices](#) for more information.
- **Phantom Power*:** Select a phantom power setting.
- **Pad/Boost*:** Select input pad or boost to avoid overloading the audio input, or increase low-output audio sources.
- **About:** Displays the firmware, hardware, and band information.

*SLXD3+ only

Setting the Transmitter RF Power

The transmitter offers multiple RF power settings which determine the transmitter range. Use the low setting when the transmitter and receiver are in close proximity.

- 1 mW (Low)
- 10 mW (High)
- 30 mW (SLXD3+ only)

To change the transmitter RF power:

1. Go to the transmitter RF power menu.
2. Use the menu button to select an RF power setting.
3. Press enter to save.

How to Use SLX-D Transmitters with SLX-D+ Receivers

Wideband SLX-D+ and narrowband legacy SLX-D receivers and transmitters are compatible when tuned to the same frequency band.

There are two ways to set up an SLX-D+ receiver to use with SLX-D transmitters:

- During IR sync, the receiver will detect a band mismatch and open the RF Band menu automatically. Push the control knob to apply the suggested change OR
- Before setting up your system, go to `Device Configuration > RF > RF Band` and select the band that matches your transmitter.

Compatible Frequency Bands for SLX-D+ and SLX-D Devices*

Region	SLX-D+ Band	Compatible SLX-D Band
USA, Canada, Latin America	G57	G58 H55 J52

Region	SLX-D+ Band	Compatible SLX-D Band
Europe, MEASA	G65	G59 H56 J53
Europe	K55	K59 L56
Europe	S50	
Israel	G60	
China	L60	L58 L59
China	G60	
Hong Kong	G54	G61
Taiwan	K60	L58
South Korea	G64	-
South Korea	X51	
Japan	JB	
Southeast Asia	G66	H57
Thailand	M55	
Australia, New Zealand	H58	H57 J54

***IMPORTANT:** Bands across regions are not compatible.

Batteries and Chargers

Battery Types

Use 2 AA batteries or a Shure SB903 rechargeable battery to power SLX-D+ transmitters.

Setting the AA Battery Type

To ensure accurate display of device runtime, set the battery type in the device menu to match the installed AA battery type. If a Shure rechargeable battery is installed, selecting a battery type is not necessary and the battery type menu will not be selectable.

To set the battery type:

1. Go to the Battery menu.
2. Press enter, then use the menu button to select the installed battery type:
 - Alkaline (default setting)
 - NiMH (nickel metal hydride)
 - Lithium (non-rechargeable, 1.5V max)
3. Press enter to save.

Shure SB903 Rechargeable Battery

The SB903 lithium-ion rechargeable battery powers the SLX-D+ transmitters. Use the SBC10-903, SBC203, or SBC80-903 chargers to recharge SB903 batteries.

IMPORTANT: Always fully charge a new battery before first use.

To fully charge a new SB903 battery, it must be placed directly in the charger. After the first charge, the battery can be charged by docking the transmitter in the SBC203 dual-bay charger.

Important Tips for Care and Storage of Shure Rechargeable Batteries

Proper care and storage of Shure batteries results in reliable performance and ensures a long lifetime.

- Always store batteries and transmitters at room temperature
- Ideally, batteries should be charged to approximately 40% of capacity for long-term storage
- During storage, check batteries every 6 months and recharge to 40% of capacity as needed

SB903 Battery Chargers

SBC10-903 Single-Bay Charger

The SBC10-903 single-bay charger offers a compact charging solution.

1. Plug the charger into an AC power source or USB port.
2. Insert a battery into the charging bay.
3. Monitor the charging status LEDs until charging is complete.

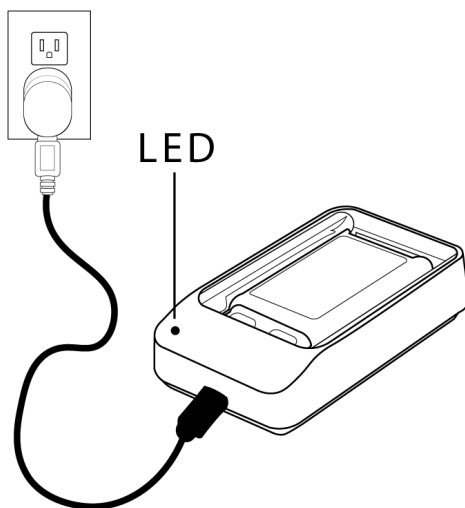

Charging Status LEDs

Description	Color	State
Ready for Use	Green (solid)	Device is fully charged
Charging	Red (flashing)	Charging
Error	Yellow (quick flashing)	Battery or power supply error
Not Charging	Off	Power supply is disconnected, or no battery is inserted in the charging bay

SBC203 Dual-Bay Charger

The SBC203 dual-bay charger can charge individual batteries or batteries installed in transmitters.

1. Plug the charger into an AC power source.
2. Insert batteries or transmitters into the charging bay.

IMPORTANT: Insert transmitters facing forward to avoid damage.

3. Monitor the charging status LEDs until charging is complete.

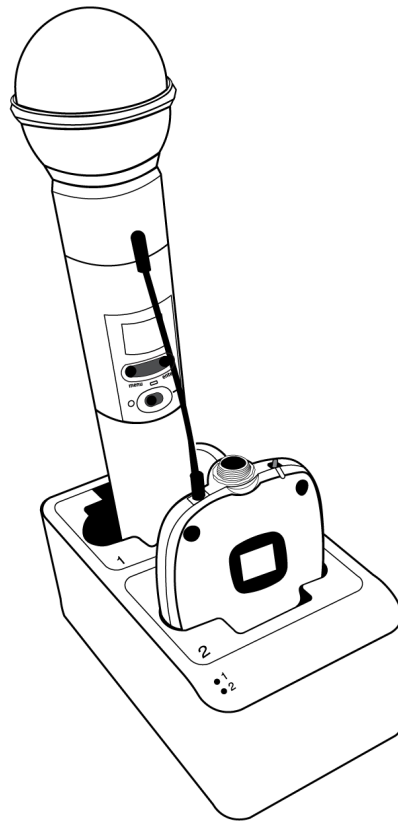

Charging Status LEDs

Description	Color	State
Ready for Use	Green (solid)	Device is fully charged
Charging	Red (flashing)	Charging
Error	Yellow (quick flashing)	Battery or power supply error*
	Yellow (slow flashing)	Outside of operating temperature range
Not Charging	Off	Power supply is disconnected, or no device is docked in the charging bay

* If an error occurs when a transmitter is docked in the charger, remove the battery from the transmitter and place directly into the charger. If the error persists, contact Shure Technical Support.

SBC80-903 Cradle Charger

The SBC80-903 cradle charger holds eight SB903 batteries and is designed to fit into a rackmount drawer. It may be used in any appropriate location with adequate space and ventilation.

1. Connect the DC power cable to the input port on the back of the charger.
2. Finger tighten the lock nut for a secure connection.
3. Connect the power cable to an AC adapter.
4. To charge, place batteries into the charging bays with slotted sides down. The LEDs illuminate to indicate battery status.

The SBC80-903 has no power switch. When plugged in, the charger is ready. The LEDs illuminate after batteries are inserted.

WARNING:

- Do not use pliers or any other tools to tighten lock nut. DC power cable must be attached before charger unit is installed.
- Do not plug in power supply unit until DC connection and charger are in place.
- After securing the charger, plug the power cable into a properly grounded outlet.

Charging Status LEDs

Description	Color	State
Ready for Use	Green (solid)	Device is fully charged
Charging	Red (flashing)	Charging
Error	Yellow (quick flashing)	Battery or power supply error
	Yellow (slow flashing)	Outside of operating temperature range
Not Charging	Off	Power supply is disconnected, or no battery is inserted in the charging bay

Average Charging Times

The following averages are based on a battery with 100% health:

SBC10-903

Time Charging	Operating Runtime	Capacity
1 hour	1 hour	15%
3 hours	4 hours	50%
5 hours : 30 minutes	>8 hours	100%

SBC203

Time Charging	Operating Runtime	Capacity
30 minutes	1 hour	15%
1 hour : 15 minutes	4 hours	50%
2 hours : 30 minutes	>8 hours	100%

SBC80-903

Time Charging	Operating Runtime	Capacity
30 minutes	1 hour	15%
1 hour : 15 minutes	4 hours	50%
2 hours : 30 minutes	>8 hours	100%

How to Set Up Your SLX-D+ System

To set up your SLX-D+ system:

1. **Set Up Hardware:** Connect antennas, install transmitter batteries, and power on devices.
2. **Network Multiple Receivers:** For multi-receiver systems, connect all SLX-D+ receivers to the same network via Ethernet.
3. **Link Transmitters and Receivers:** For initial setup, pair SLX-D+ transmitters and receivers via ShowLink Ease.
4. **Coordinate Frequencies:** Perform a scan of the RF spectrum to find compatible frequencies when initializing your system or adding a receiver to an existing system.

Step 1: Set Up SLXD4+ or SLXD4D+ Hardware

1. Attach the included antennas to the back of the receiver.

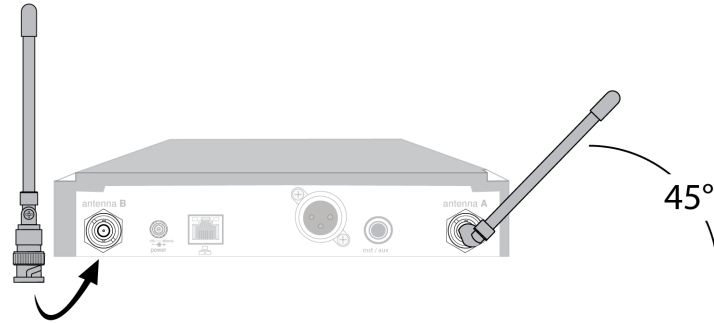

2. Connect the power supply to the receiver and plug the cord into an AC power source.

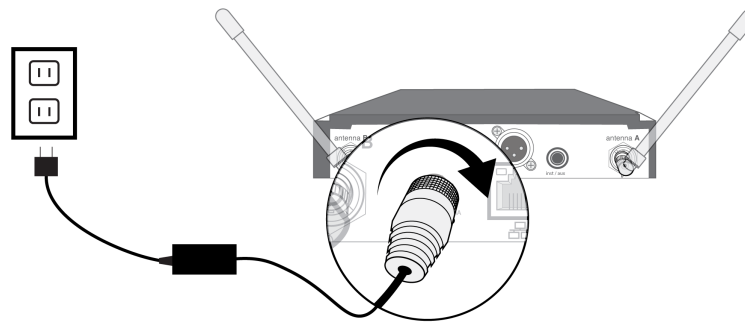

3. Connect the audio output to an amplifier or mixer.

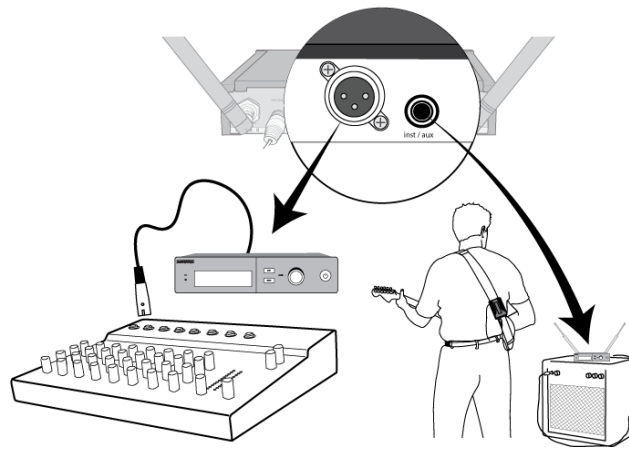

4. Press the power button on the receiver. Use the menu to set the system to microphone (mic) or instrument (line) level as appropriate.

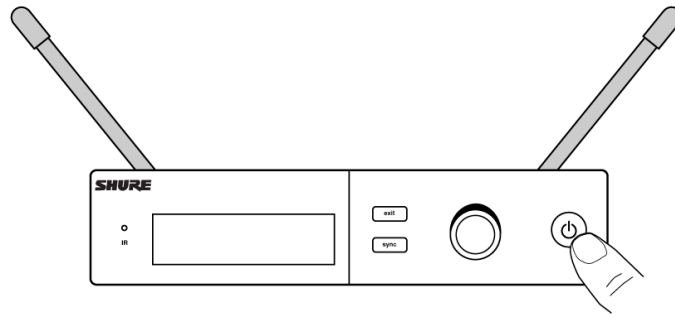

Install Transmitter Batteries

IMPORTANT: To avoid damaging transmitters, only use Shure SB903 Li-ion rechargeable batteries or 1.5V AA batteries.

Bodypack / Plug-On:

1. Push the tab up and open the battery door to access the battery compartment.
2. Place a Shure SB903 Li-ion rechargeable battery or 2 AA batteries in the compartment.
3. Close the battery door.

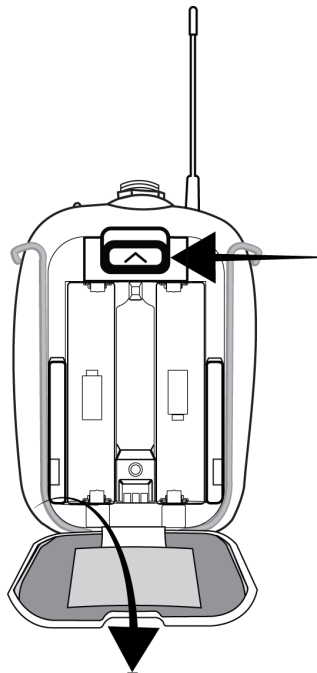

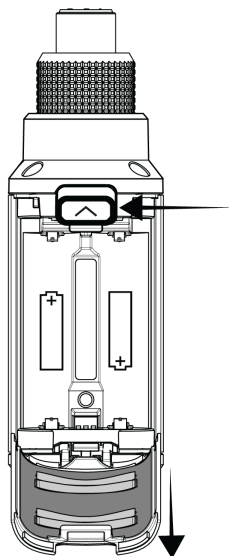

Handheld:

1. Remove the battery cover to access the battery compartment.
2. Lift the battery door to open the battery compartment.
3. Place a Shure SB903 Li-ion rechargeable battery or 2 AA batteries in the compartment.
4. Replace the battery cover.

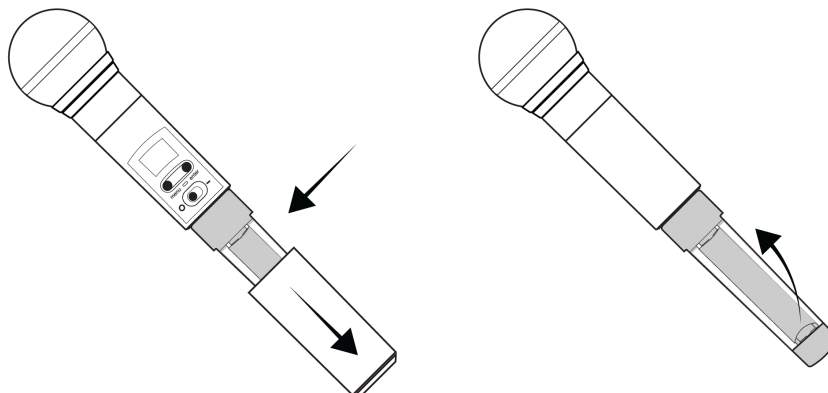

Step 2: Network Multiple Receivers

Multi-receiver systems must use an Ethernet connection to network with other devices in the system for proper RF coordination, deployment of frequencies, and control functions.

To set up systems with multiple receivers:

1. Insert an Ethernet cable in the Ethernet port on the rear of the receiver.
2. Connect the cable to a network switch or router.
3. The port LEDs on the receiver will illuminate to indicate network connectivity and network traffic.

IP Address Configuration

An IP address must be assigned to each device in the network to ensure communication and control between devices. Valid IP addresses can be assigned automatically using a DHCP server or manually from a list of valid IP addresses.

How to Configure IP Address

1. Go to Device Configuration > Connectivity > Network Setup > start setup.
2. Use the control knob to select Automatic or Manual. For Manual, enter the IP settings.
3. Push the control knob to apply and save changes.

Networking Configuration Tips

- Use shielded Cat5 (or higher) Ethernet cables to ensure reliable network performance
- Use only one DHCP server per network
- All devices must operate on the same subnet mask
- All receivers must have the same level of firmware version installed
- The LEDs on the Ethernet port illuminate indicating a network connection is active
- The network icon illuminates when the receiver detects additional Shure devices on the network
- Use multiple Ethernet switches to extend the network for larger installations

Step 3: Link Transmitters and Receivers

To link SLX-D+ transmitters and receivers:

1. Align the infrared (IR) ports on the transmitter and receiver.
2. Push the sync button. A double-arrow icon  displays on both devices when linked successfully via ShowLink Ease.

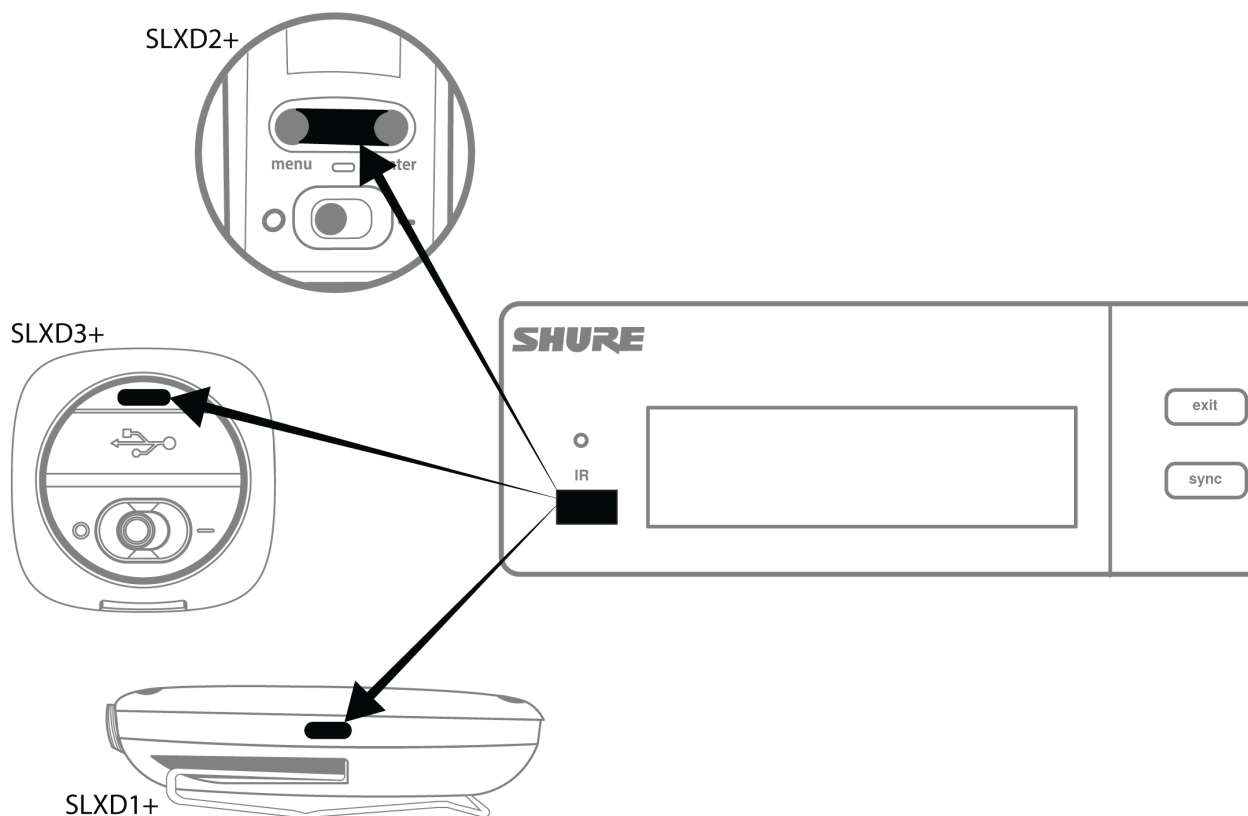

What is ShowLink Ease?

ShowLink Ease allows you to remotely adjust transmitter settings from the receiver menu, update transmitter firmware, and deploy frequencies to both devices during frequency coordination setup and during interference management without needing to

resync.* Devices maintain the link even after power cycles. ShowLink Ease operates within a range of 100 ft (30 m) and an unobstructed line of sight.

*Transmitters must be resynced after updating audio encryption settings or after a factory reset.

Linking Two Transmitters to a Receiver

Linking two transmitters to a receiver offers the flexibility to provide a performer with either a handheld or bodypack transmitter to meet their preference. For performances requiring instrument changes, two bodypack transmitters can be linked to a single receiver.

IMPORTANT: Only turn on and operate one transmitter at a time to prevent interference between the transmitters.

How to Add a Second Transmitter Link

Both transmitters must be individually linked to the receiver by performing an IR sync. The receiver menu will not show the option to link a second transmitter until the first transmitter has been linked to the receiver.

1. Turn on the first transmitter and perform an IR sync with the receiver.
2. Turn off the first transmitter.
3. From the receiver, go to **Transmitter > Add Second Tx Link**.
4. Turn on the second transmitter and perform an IR sync with the receiver.

Match Audio Levels with Mic Offset

When linking two transmitters to a receiver, there may be a difference in volume levels between microphones or instruments. If this occurs, use the Mic Offset function to match the audio levels and eliminate audible volume differences between transmitters. If using a single transmitter, set Mic Offset to 0 dB.

1. Turn on the first transmitter and perform a sound check to test the audio level. Turn off the transmitter when finished.
2. Turn on the second transmitter and perform a sound check to test the audio level.
3. If there is an audible difference in the sound level between the transmitters, go to the Mic Offset menu on the transmitter to increase or decrease the dB to match the audio levels.



Step 4: Coordinate Frequencies

Frequency coordination prevents interference between wireless systems by scanning the RF spectrum for the best available frequency to deploy to your devices.

What are Groups and Channels?

To minimize interference, Shure wireless systems organize RF bands into predefined **groups** and **channels**. A group is a set of compatible frequencies within a frequency band. A single frequency within a group is a channel. Tune a receiver and transmitter to the best available channel within its group to set up your system.

Note: All receivers in the same band should be set to the same group. Because groups are band-dependent, some systems don't have multiple groups. Single-group bands have the same RF performance as those with multiple groups.

IMPORTANT: Before you begin frequency coordination, systems with multiple receivers must be connected to the same network and transmitters and receivers must be linked via ShowLink Ease.

Frequency Scan for a New System

To set up a new wireless system:

1. Go to Frequency Setup > Initialize My System and push the control knob to continue.
2. Push the control knob again to select start scan.
3. After the scan completes, push the control knob to select assign.*

Frequency Scan to Add a Receiver

To add a new receiver to your system:

1. Go to Frequency Setup > Add Receiver to My System and push the control knob to continue.
2. Use the same group number on all receivers in your system. To change the group, rotate the control knob to select the group number, push the knob, rotate to change the number, and push again to confirm.
3. Push the control knob to select start scan.
4. After the scan completes, push the control knob to select apply.*

Frequency Scan for a Single Channel

To find a compatible frequency for an individual receiver channel:

1. Go to Frequency Setup > Single Channel Scan and push the control knob to continue.
2. Push the control knob again to select start scan.
3. After the scan completes, push the control knob to select assign.*

Manually Select Frequencies

To manually select frequencies:

1. Go to Frequency Setup > Manual Frequency Setup and select and adjust the group (G), channel (C), or frequency (MHz) as needed.
2. Select apply to confirm and save your settings.*

*Frequencies will automatically deploy to transmitters linked via ShowLink Ease.

Device Management

Gain Adjustment

Go to Audio Settings > Gain to test the transmitter at performance levels. Adjust the gain to keep the audio indicator within the optimal range. Reduce the gain if there is audible distortion of the audio.

Note: To replicate the output level of an instrument and achieve unity gain, set receiver gain to -18 dB, use an unbalanced ¼" cable, set output level to line, and set mic offset to 0.

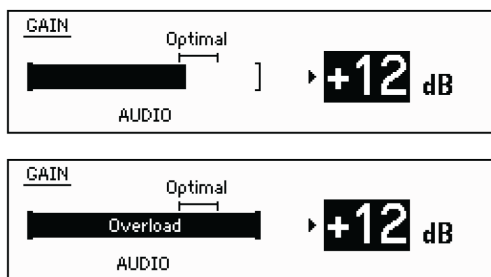

Locking and Unlocking Devices

Receivers and transmitters can be locked to prevent unauthorized setting changes or accidental power-off. The following control lock options are available:

- **Unlock:** receiver controls are unlocked
- **Menu Only:** prevents access to menu items
- **Menu & Power:** disables the power switch and menu controls

Locking Receivers

1. Go to **Device Configuration > Device Settings > Device Lock**.
2. Select the desired control lock option and push the control knob to confirm.

Locking Transmitters

Use auto lock to lock and unlock transmitter controls. When auto lock is enabled, transmitter controls lock when you return to the home screen. The enter button can still be used to change the home screen display on a locked transmitter.

To lock transmitters:

1. Go to the **Lock Type** menu and select a control lock option.
2. Go to the **Auto Lock** menu.
3. Press enter then menu to select **On**. Auto lock must be on for the transmitter to lock.
4. Press enter to save. A lock icon appears on the display to confirm that locks are enabled.

To unlock the transmitter and deactivate auto lock:

1. Press enter then menu to unlock the transmitter controls.
2. Go to **Auto Lock** and press enter then menu to select **Off**.
3. Press enter to save. The transmitter will no longer lock when you return to the home screen.

Audio Summing

Audio summing combines input signals and sends them over a single output channel. This makes it possible to send all channels to a device with a limited number of receiver channels or analog inputs. Summed audio is available on all outputs.

To combine channels, go to **Device Configuration > Audio > Audio Summing** and select one of the audio summing options.

Note: Audio summing is available on dual receivers only.

1 + 2

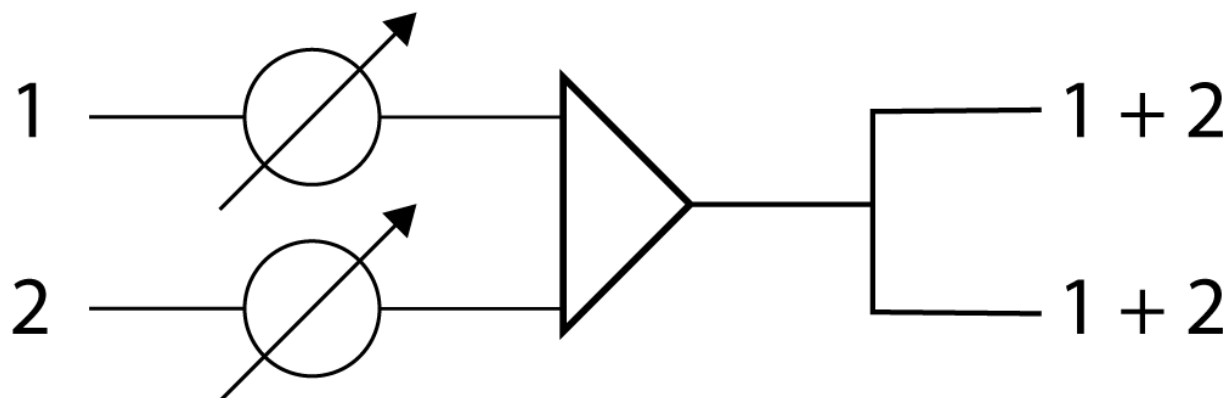

Interference Management

SLX-D+ monitors the RF environment for potential sources of interference that could cause audio dropouts. In the event of signal degradation, interference management technology provides options to move to a clean, compatible frequency. Respond to an alert by manually selecting a new frequency, or allow the device to automatically deploy a backup frequency the instant interference is detected.

Setting the Interference Management Mode

Set the interference management mode to determine how the receiver will respond in the event of interference. To choose an interference management mode:

1. Go to **Device Configuration > RF > Interference Management**.
2. Choose one of the following modes:
 - Alert (default): interference alert appears on display
 - Manual: alert appears on display, then prompts you to press control knob and manually select a new frequency
 - Automatic: receiver automatically scans and deploys a new frequency to the receiver and linked transmitter*

*For automatic mode to function, you must set the receiver to a group that does not display dashes, and transmitters must be powered on, linked via ShowLink Ease, and within range of the receiver.

Digital Feedback Reduction (DFR)

Digital feedback reduction detects feedback and deploys up to 16 filters to reduce feedback frequencies for individual channels. Enable feedback reduction individually for each channel, as necessary.

How to Enable Digital Feedback Reduction

1. Go to **Audio Settings > Feedback Reduction**.
2. Select **On** to reduce feedback. Filters are active and change in real-time based on the sound environment.
3. Repeat as necessary for each channel.

Note: Turn digital feedback reduction off to reset all filters.

Locking Digital Feedback Reduction Filters

When feedback reduction is on and at least one filter is engaged, you can lock filters to prevent further changes. Engaged filters remain the same when locked, even after power cycling. To lock filters:

1. From the Feedback Reduction menu screen, push the control knob and scroll to select Lock.
2. Scroll again to view the filtered frequency list.

Audio Encryption

Advanced Encryption Standard (AES-256) ensures secure audio transmission between a receiver and transmitter. When encryption is enabled, the receiver generates a unique encryption key which is shared with the transmitter after IR sync. Transmitters and receivers that share an encryption key form a protected audio path, preventing unauthorized access by other receivers. To maintain security, devices remain encrypted between power cycles.

IMPORTANT: Encryption is not shared via ShowLink Ease, so devices must be resynced when the encryption status changes from on or off.

To enable encryption:

1. Go to Device Configuration > Audio > Audio Encryption.
2. Select On. All linked transmitters will be unlinked from the receiver.
3. IR sync the transmitter and receiver. A key icon appears on the receiver and transmitter display when encryption is on.

Coordination and Management Tools

Using Wireless Workbench with SLX-D+

Wireless Workbench enables remote adjustments for devices in your wireless system so you can manage essential tasks, such as inventory setup, frequency coordination, device monitoring, and real-time changes to gain, RF power, and control locks. Wireless Workbench is available on desktop and mobile.

Shure devices can connect to the software with Ethernet, Wi-Fi, or Bluetooth. Visit the [Wireless Workbench desktop quick start guide](#) or [Wireless Workbench Mobile app user guide](#) for connection diagrams. See [Connect to Wireless Workbench Mobile via Bluetooth](#) for more information on how to set up Bluetooth pairing for SLX-D+ receivers.

Connect to Wireless Workbench Mobile via Bluetooth

Connect up to 7 SLX-D+ receivers directly to Wireless Workbench Mobile. To connect devices:

1. Enable Bluetooth on your mobile device.
2. From the receiver display, go to Device Configuration > Connectivity > App Connection > Allow app control and confirm app control is on.
3. Scroll to Pairing Mode and push the control knob to select. A unique device ID will show on the display.
4. From the app, go to main menu > Bluetooth and select the device that matches the device ID on the receiver display.
5. Enter a name for your mobile device and tap Connect. This name appears on the SLX-D+ receiver display so you know which mobile device your system is connected to.
6. Tap Pair to confirm. Channels appear in the inventory list when the device is connected, and the receiver will display a success screen and a Bluetooth icon.

Connecting to an External Control System

SLX-D+ receivers are compatible with external control systems, such as AMX or Crestron, via Ethernet. Use only one controller per system to avoid messaging conflicts.

- Connection: Ethernet (TCP/IP; SLX-D+ receiver is the client)

- Port: 2202

SLX-D+ blocks command strings by default. To enable access for control strings, go to Device Configuration > Device Settings > Controller Access and select Allow.

For a comprehensive list of SLX-D+ command strings, visit <https://www.shure.com/en-US/docs/commandstrings/SLXDplus>.

Firmware

It is best practice for all devices to operate on the same firmware version. Go to the About screen of your devices to view the firmware version.

The format for Shure device firmware is MAJOR.MINOR.PATCH.BUILD (example: 1.2.21.1). At a minimum, all devices on the same network must have identical MAJOR and MINOR firmware version numbers (example: 1.2.x.x).

New versions of firmware can be uploaded and installed using the Shure Update Utility (SUU). Download the SUU from https://www.shure.com/en-US/products/software/shure_update_utility.

CAUTION! Ensure the device has a stable network connection during the update. Do not turn off the device until the update is complete.

Updating Receiver Firmware

1. Connect the device and computer to the same network (set to the same subnet).
2. Open the SUU application.
3. Click the updates button at the top of the window to open the Download Manager.

Note: This button will be labeled either "Check for updates..." or "[#] updates available"

4. From the Download Manager, select the desired firmware versions.
5. Click Download, then close the Download Manager. Downloaded firmware can be viewed and managed in the Firmware tab.
6. From the Update Devices tab, select the new firmware and click Send Updates.

Updating Transmitter Firmware

Transmitter firmware updates are managed from the receiver. Confirm the receiver is operating the latest firmware version, then update transmitters using one of the following methods:

Via IR Sync

1. From the receiver, go to Transmitter > Transmitter Firmware > Update via IR.
2. Align the infrared (IR) ports on the transmitter and receiver, then push the sync button. Alignment must be maintained during the entire update cycle.
3. Once the sync is complete, the system is ready for use.

Via ShowLink Ease

1. Power on linked transmitters and place near the receiver.
2. From the receiver, go to Transmitter > Transmitter Firmware > Update via ShowLink Ease.
3. Once the transmitter display returns to the home screen, the update is complete and the system is ready for use.

When updating via ShowLink Ease, multi-channel receivers update all linked transmitters one after another. Transmitters that fail to update are skipped, and failure details appear on the receiver channel display.

Rack Mounting the Receiver

All accessories are supplied:

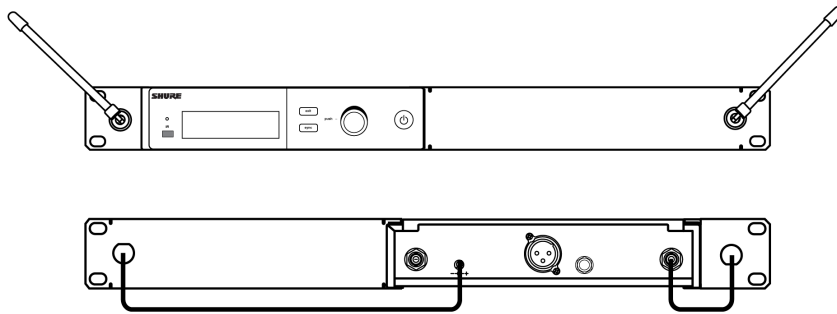
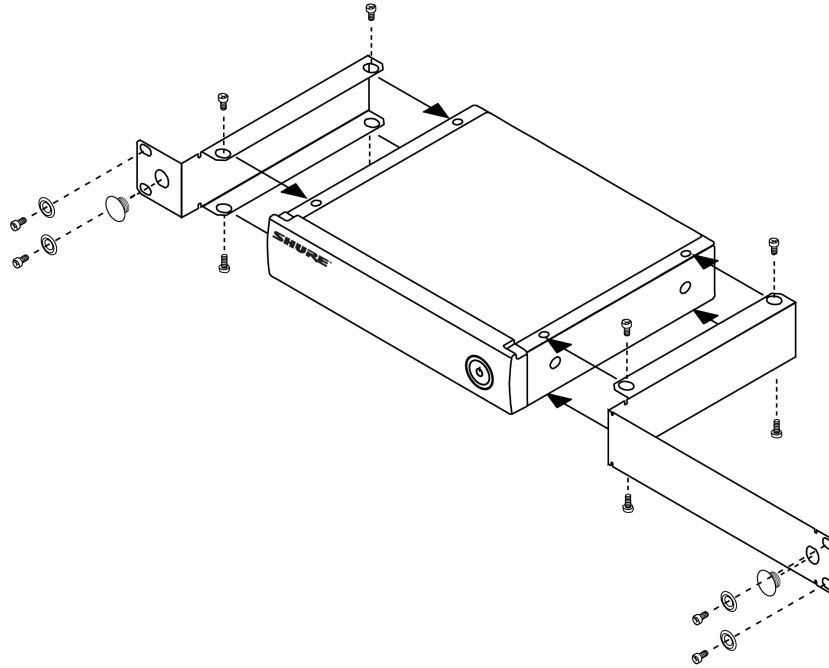

Installing Footpads

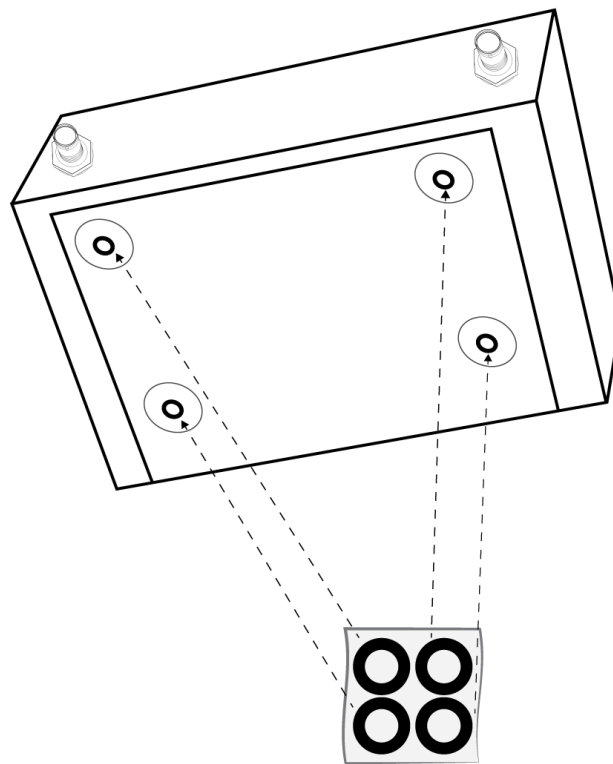

Optional Accessories

Batteries and Chargers

Shure Lithium-Ion Rechargeable Battery	SB903
8-Bay Cradle Charger	SBC80-903-AR
	SBC80-903-AZ
	SBC80-903-BR
	SBC80-903-CN
	SBC80-903-E
	SBC80-903-IN
	SBC80-903-J
	SBC80-903-K
	SBC80-903-TW
	SBC80-903-UK

	SBC80-903-US
Dual Docking Charger	SBC203-AR
	SBC203-AZ
	SBC203-BR
	SBC203-CN
	SBC203-E
	SBC203-IN
	SBC203-J
	SBC203-K
	SBC203-TW
	SBC203-UK
	SBC203-US
Single Battery Charger	SBC10-903-AR
	SBC10-903-AZ
	SBC10-903-BR
	SBC10-903-CN
	SBC10-903-E
	SBC10-903-IN
	SBC10-903-J
	SBC10-903-K
	SBC10-903-TW
	SBC10-903-UK
	SBC10-903-US

UHF Antenna Power Distribution Amplifiers

Antenna/Power Distribution System 470-960 MHz	UA844+SWB
	UA844+SWB-AR
	UA844+SWB-AZ
	UA844+SWB-BR
	UA844+SWB-C
	UA844+SWB-E

	UA844+SWB-J
	UA844+SWB-K
	UA844+SWB-TW
	UA844+SWB-UK
	UA844+SWB-IN
Antenna/Power Distribution System, Less cable 470-960 MHz	UA844+SWB/LC
	UA844+SWB/LC-AR
	UA844+SWB/LC-BR
	UA844+SWB/LC-C
	UA844+SWB/LC-E
	UA844+SWB/LC-UK
Ultra Wideband Antenna/Power Distribution System 174-1805 MHz	UA845UWB
	UA845UWB-AR
	UA845UWB-AZ
	UA845UWB-BR
	UA845UWB-C
	UA845UWB-E
	UA845UWB-IN
	UA845UWB-J
	UA845UWB-K
	UA845UWB-TW
	UA845UWB-UK
Ultra Wideband Antenna/Power Distribution System, Less cable 174-1805 MHz	UA845UWB/LC
	UA845UWB/LC-AR
	UA845UWB/LC-BR
	UA845UWB/LC-E
	UA845UWB/LC-UK

UABIAST

In-Line Power Supply	UABIAST-US
	UABIAST-UK

	UABIAST-BR
	UABIAST-AR
	UABIAST-E
	UABIAST-CHN
	UABIAST-IN
	UABIAST-K
	UABIAST-J
	UABIAST-AZ
	UABIAST-TW

In-Line Amplifiers and Antennas

In-Line Antenna Amplifier, 470-900 MHz	UA834WB
In-Line Antenna Amplifier, 902-960 MHz	UA834XA
Active Directional Antenna 470-790 MHz	UA874E
Active Directional Antenna 470-698 MHz	UA874US
Active Directional Antenna 470-900 MHz	UA874WB
Active Directional Antenna 925-952 MHz	UA874X
Directional Wideband Antenna for PSM Systems 470-952 MHz	PA805SWB
Directional Wideband Antenna for PSM Systems 650-1100 MHz	PA805X
Passive Omnidirectional Antenna 470-1100 MHz	UA860SWB
UHF Passive Antenna Splitter	UA221
Front Mount Antenna Kit (Includes 2 Cables And 2 Bulk-head)	UA600
Remote Antenna Bracket With BNC Bulkhead Adaptor	UA505
Helical Antenna, 470-900MHz	HA-8089

Cables, Cases and Connectors

Coaxial Cable, BNC-BNC, RG58C/U TYPE, 50 OHM, 2 FT Length (0.6 M)	UA802
Coaxial Cable, BNC-BNC, RG58C/U TYPE, 50 OHM, 6 FT Length (2 M)	UA806

Coaxial Cable, BNC-BNC, RG8X/U TYPE, 50 OHM, 25 FT Length (7.5 M)	UA825
Coaxial Cable, BNC-BNC, RG8X/U TYPE, 50 OHM, 50 FT Length (15 M)	UA850
Coaxial Cable, BNC-BNC, RG213/U TYPE, 50 OHM, 100 FT Length (30 M)	UA8100
Ethernet Jumper Cable, 8"	C8006
Ethernet Cable, 3 FT.	C803
Ethernet Cable, 10 FT.	C810
Ethernet Cable, Ruggedized, 25 FT.	C825
Ethernet Cable, Ruggedized, 50 FT.	C850
Ethernet Cable, Ruggedized, 100 FT.	C8100

1/2 Wave Omnidirectional Receiver Antennas

470-542 MHz	UA8-470-542
500-560 MHz	UA8-500-560
518-598 MHz	UA8-518-598
554-638 MHz	UA8-554-638
596-698 MHz	UA8-596-698
670-742 MHz	UA8-670-742
690-746 MHz	UA8-690-746
694-758 MHz	UA8-694-758
710-790 MHz	UA8-710-790
740-814 MHz	UA8-740-814
750-822 MHz	UA8-750-822
774-865 MHz	UA8-774-865
00-1000 MHz	UA8-900-1000

Specifications

System RF

RF Carrier Frequency Range

470–937.5 MHz, varies by region (See Frequency Range and Output Power table)

Working Range

100 m (328 ft)

Note: Actual range depends on RF signal absorption, reflection and interference.

RF Tuning Step Size

25 kHz, varies by region

JB band: 125 kHz

Image Rejection

>85 dB, typical

RF Sensitivity

-97 dBm at 10^{-5} BER

System Temperatures

Operating Temperature Range

-18°C (0°F) to 50°C (122°F)

Note: Battery characteristics may limit this range.

Storage Temperature Range

-29°C (-20°F) to 74°C (165°F)

Note: Battery characteristics may limit this range.

System Audio

Latency

2.8 ms

High-Pass / Low Cut Filter

160 Hz @ -12 dB/octave

Note: Factory default is for the HPF to be off

Audio Dynamic Range

118 dB at 1% THD, A-weighted, typical

Total Harmonic Distortion

<0.02%

System Audio Polarity

Positive pressure on microphone diaphragm produces positive voltage on pin 2 with respect to pin 3 of XLR output, and the tip of the 6.35 mm (¼ in.) with respect to the ring of the 6.35 mm output.

Mic Offset Range

0 to 21 dB (in 3 dB steps)

Bluetooth (BLE)**Frequency Range**

2402–2480 MHz

RF Power

10 mW EIRP

Modulation Type

BLE (GFSK)

Antenna Type

Chip

Antenna Gain

-0.7 dBi

SLXD4+ and SLXD4D+ Rack Receiver**Dimensions**

SLXD4+	42 x 197 x 152 mm (1.65 x 7.76 x 5.98 in.), H x W x D
SLXD4D+	42 x 197 x 152 mm (1.65 x 7.76 x 5.98 in.), H x W x D

Weight

SLXD4+	900 g, without antennas
SLXD4D+	930 g, without antennas

Housing

Galvanized Steel

Power Requirements

15 V DC @ 360 mA, supplied by external power supply (tip positive)

RF Input**Spurious Rejection**

>75 dB, typical

Connector Type

BNC

Impedance

50 Ω

Phantom Power Protection

1/4" (6.35 mm)	Yes
XLR	Yes

Audio Output

Audio Frequency Response

20 Hz– 20 kHz (+1, -2 dB)

Gain Adjustment Range

-18 to +42 dB in 1 dB steps

Configuration

1/4" (6.35 mm)	Balanced (Tip = audio +, Ring = audio -, Sleeve = ground)
XLR	Balanced (1=ground, 2=audio +, 3=audio -)

Impedance

1/4" (6.35 mm)	1.1 k Ω (550 Ω Unbalanced)
XLR (line)	500 Ω (250 Ω Unbalanced)
XLR (mic)	150 Ω

Full Scale Output

1/4" (6.35 mm)	+18 dBV differentially (+12 dBV single)
XLR	LINE setting = +18 dBV, MIC setting = -12 dBV

Mic/Line Switch

30 dB pad

Networking

Network Interface

Single Port Ethernet 10/100 Mbps

Network Addressing Capability

DHCP or Manual IP address

Maximum Cable Length

100 m (328 ft)

SLXD1+ Bodypack Transmitter

Battery Type

Rechargeable Li-Ion or 1.5 V AA batteries

Dimensions

98 x 68 x 25.5 mm (3.86 x 2.68 x 1 in.), H x W x D

Weight

89 g

Housing

PC/ABS

Audio Input

Connector

4-Pin male mini connector (TA4M)

Configuration

See drawing for details

Impedance

1 M Ω

Maximum Input Level

8.2 dBV (2.57 V_{rms}, 7.27 V_{pp})

Preamplifier Equivalent Input Noise (EIN)

-118 dBV

RF Output

Antenna Type

1/4 wave

Occupied Bandwidth

<200 kHz

Modulation Type

Shure proprietary digital

Power

1 mW or 10 mW

See Frequency Range and Output Power table, varies by region

SLXD2+ Handheld Transmitter

Battery Type

Rechargeable Li-Ion or 1.5 V AA batteries

Dimensions

37.1 x 176 mm (1.46 x 6.93 in.), D x L

Weight

144 g

Housing

Aluminum

Audio Input

Configuration

See drawing for details

Maximum Input Level

8.2 dBV (2.57 Vrms, 7.27 Vpp)

Note: Dependent on microphone type

RF Output

Antenna Type

Integrated Single Band Helical

Occupied Bandwidth

<200 kHz

Modulation Type

Shure proprietary digital

Power

1 mW or 10 mW

See Frequency Range and Output Power table, varies by region

SLXD3+ Plug-On Transmitter

Battery Type

Rechargeable Li-Ion or 1.5 V AA batteries

Dimensions

126 x 41 x 41 mm (4.96 x 1.61 x 1.61 in.), LxWxD

Weight

200 g

Housing

Aluminum, zinc alloy, PC/ABS

Audio Input**Connector Type**

XLR

See drawing for details

Maximum Input Level

Pad -12 dB	20.5 dBV
0 dB	8.5 dBV
Boost +12 dB	-3.5 dBV

1 kHz at 1% THD

Note: Dependent on microphone type

Phantom Power

+48 V (7 mA maximum), +12 V (15 mA maximum)

RF Output**Antenna Type**

Dipole

Occupied Bandwidth

<200 kHz

Modulation Type

Shure proprietary digital

Power

1 mW / 10 mW / 30 mW

See Frequency Range and Output Power table, varies by region

SB903 Rechargeable Battery**Charge Voltage**4.2 V (± 0.03 V)

Charge Current

SBC10-903	220 mA
SBC203	625 mA (normal), 250 mA (reduced)*
SLXD3+	650 mA
SLXD5+	600 mA

*Normal = 10 °C to 45 °C (50 °F to 113 °F), reduced = 0 °C to 10 °C (32 °F to 50 °F)

Nominal Voltage

3.6 V

Nominal Capacity

1200 mAh

Housing

Molded Polycarbonate

Charging Temperature Range

0 °C to 45 °C (32 °F to 113 °F)

Dimensions

14.5 x 32.5 x 55.5 mm (0.57 x 1.28 x 2.19 in.), H x W x D

Weight

28 g

SBC10-903 Battery Charger

DC Input Voltage Range

5 V DC

Charge Current

USB-powered

220 mA

Charge Time

50% = 3 hours; 100% = 5 hours : 30 minutes

External Power Supply

SBC10-USB

Power Requirements

5 V DC, 1 A max.

Operating Temperature Range

0 °C to 45 °C (32 °F to 113 °F)

Dimensions

20.5 x 37.5 x 79.5 mm (0.81 x 1.48 x 3.13 in.), H x W x D

Weight

39 g

Housing

Molded Polycarbonate

SBC203 Battery Charger

Charge Current

625 mA or 250 mA

Lower current used when using another power source, or operating between 0°C and 10°C

Charge Time

50% = 1 hour : 15 minutes; 100% = 2 hours : 30 minutes

External Power Supply

SBC10-USB15W or SBC10-USB15WS

Power Requirements

5 V DC, 3 A max.

Operating Temperature Range

0 °C to 45 °C (32 °F to 113 °F)

Dimensions

66.3 x 86.0 x 155 mm (2.61 x 3.38 x 6.13 in.), H x W x L

Weight

284 g

Housing

ABS

SBC80-903 8-Bay Battery Charger

Charge Current

625 mA

Charge Time

50%=1 hour; 100%=3 hours

External Power Supply

PS60

Power Requirements

15V DC, 4A

Dimensions

30 mm x 173 mm x 146 mm (1.18 in. x 6.81 in. x 5.75 in.), H x W x D

Weight

375 g (13.2 oz.)

Storage Temperature Range

-20°F to 165°F (-29°C to 74°C)

Charging Temperature Range

32°F to 113°F (0°C to 45°C)

Receiver Output Connectors

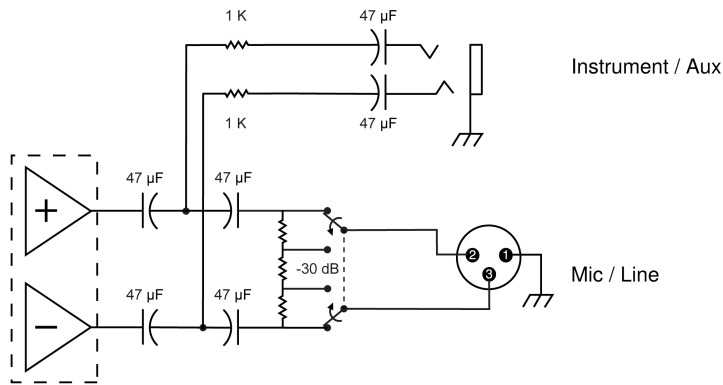

Transmitter Input

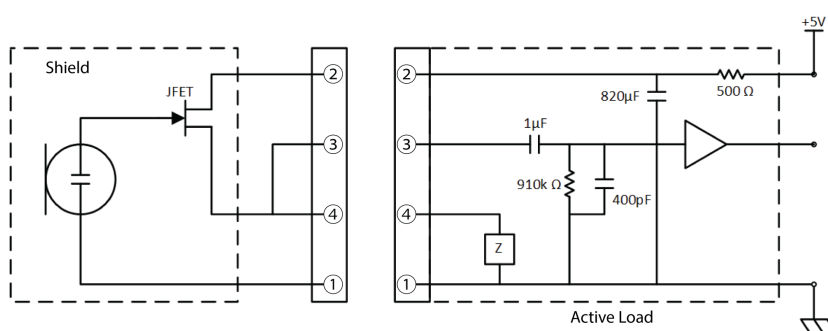

SLXD1+/SLXD2+

1. Ground
2. Bias Voltage
3. Audio Input
4. Active Load

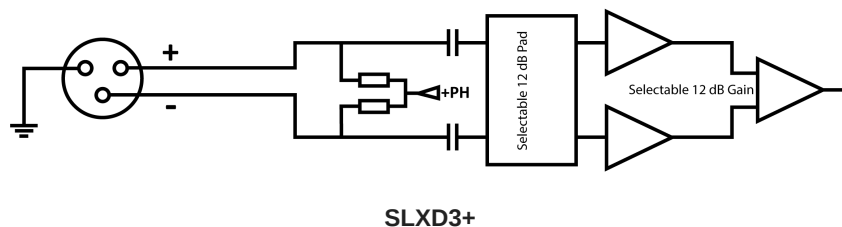

Frequency Range and Transmitter Output Power

Band	Frequency Range (MHz)	Power (mW RMS)* (Low/High)
G54	479 to 565	1 / 10
G57†	470 to 608	1 / 10 / 30**
G60	470 to 510	1 / 10 / 30**
G64	470 to 616	1 / 10 / 30**
G65	470 to 606	1 / 10 / 30**
G66	487 to 606	1 / 10
H58	520 to 606	1 / 10 / 30**
JB	806 to 810	1 / 10
K55	606 to 694	1 / 10 / 30**
K60	614 to 703	1 / 10
L60	630 to 698	1 / 10 / 30**
M55	694 to 703, 748 to 758	1 / 10 / 30**
S50	823 to 832, 863 to 865	1 / 10
X51	925 to 937.5	1 / 10

* Power delivered to the antenna port

** SLXD3 and SLXD3+ only

† Operation mode varies according to region. The maximum power level for Peru is 10mW.

Note: Frequency bands might not be available for sale or authorized for use in all countries or regions.

Frequencies for European Countries





	Frequency Range	Country Code
SLXD-G60	470 - 510 MHz*	
SLXD-G65	470 - 606 MHz*	A, B, BG, CH, CY, CZ, D, EST, F, GB, GR, H, I, IS, L, LT, NL, P, PL, S, SK, SLO, DK, FIN, M, N, HR, E, IRL, LV, RO, TR
SLXD-K55	606–694 MHz*	
SLXD-S50	823–832, 863–865 MHz *	

* This equipment may be capable of operating on some frequencies not authorized in your region.

Safety and Regulatory Information for Wireless Products

Explanation of Symbols

	This symbol indicates that dangerous voltage constituting a risk of electric shock is present within this unit.
	This symbol indicates that there are important operating and maintenance instructions in the literature accompanying this unit.

Important Safety Instructions

1. READ these instructions.
2. KEEP these instructions.
3. HEED all warnings.
4. FOLLOW all instructions.
5. DO NOT use this apparatus near water.
6. CLEAN ONLY with dry cloth.
7. DO NOT block any ventilation openings. Allow sufficient distances for adequate ventilation and install in accordance with the manufacturer's instructions.
8. DO NOT install near any heat sources such as open flames, radiators, heat registers, stoves, or other apparatus (including amplifiers) that produce heat. Do not place any open flame sources on the product.
9. DO NOT defeat the safety purpose of the polarized or grounding type plug. A polarized plug has two blades with one wider than the other. A grounding type plug has two blades and a third grounding prong. The wider blade or the third prong are provided for your safety. If the provided plug does not fit into your outlet, consult an electrician for replacement of the obsolete outlet.
10. PROTECT the power cord from being walked on or pinched, particularly at plugs, convenience receptacles, and the point where they exit from the apparatus.
11. ONLY USE attachments/accessories specified by the manufacturer.
12. USE only with a cart, stand, tripod, bracket, or table specified by the manufacturer, or sold with the apparatus. When a cart is used, use caution when moving the cart/apparatus combination to avoid injury from tip-over.



13. UNPLUG this apparatus during lightning storms or when unused for long periods of time.
14. REFER all servicing to qualified service personnel. Servicing is required when the apparatus has been damaged in any way, such as power supply cord or plug is damaged, liquid has been spilled or objects have fallen into the apparatus, the apparatus has been exposed to rain or moisture, does not operate normally, or has been dropped.
15. DO NOT expose the apparatus to dripping and splashing. DO NOT put objects filled with liquids, such as vases, on the apparatus.
16. The MAINS plug or an appliance coupler shall remain readily operable.
17. The airborne noise of the Apparatus does not exceed 70dB (A).
18. Apparatus with CLASS I construction shall be connected to a MAINS socket outlet with a protective earthing connection.
19. To reduce the risk of fire or electric shock, do not expose this apparatus to rain or moisture.
20. Do not attempt to modify this product. Doing so could result in personal injury and/or product failure.
21. Operate this product within its specified operating temperature range.
22. Follow local regulations and consult qualified personnel if the product installation or relocation requires construction work. Choose mounting hardware and an installation location that can support the weight of the product. Avoid locations subject to constant vibration. Use the required tools to install the product properly. Inspect the product periodically.
23. If your product has a feature to log in, upon first time start up, you must change your password.

WARNING:

- Voltages in this equipment are hazardous to life. No user-serviceable parts inside. Refer all servicing to qualified service personnel. The safety certifications do not apply when the operating voltage is changed from the factory setting.
- If water or other foreign objects enter the inside of the device, fire or electric shock may result.

Safety and Regulatory Information for Battery Chargers

1. This equipment is intended to be used in professional audio applications.
2. Use this battery charger only with the Shure charging modules and battery packs for which it is designed. Use with other than the specified modules and battery packs may increase the risk of fire or explosion.
3. Changes or modifications not expressly approved by Shure Incorporated could void your authority to operate this equipment.

Safety Information for Batteries

1. Battery packs may explode or release toxic materials. Risk of fire or burns. Do not open, crush, modify, disassemble, heat above 140°F (60°C), or incinerate.
2. Follow instructions from manufacturer
3. Only use Shure charger to recharge Shure rechargeable batteries

WARNING:

Danger of explosion if battery incorrectly replaced. Replace only with same or equivalent type.

Do not dispose of the battery along with household waste. Check with local vendor for proper disposal of used battery packs.

4. Never put batteries in mouth. If swallowed, contact your physician or local poison control center
5. In the event of a cell leaking, do not allow the liquid to come in contact with the skin or eyes. If contact has been made, wash the affected area with copious amounts of water and seek medical advice.
6. Do not short circuit; may cause burns or catch fire
7. Do not charge or use battery packs other than Shure rechargeable batteries
8. Batteries (battery pack or batteries installed) shall not be exposed to excessive heat such as sunshine, fire or the like
9. Do not immerse the battery in liquid such as water, beverages, or other fluids.
10. Do not attach or insert battery with polarity reversed.
11. Keep away from small children.
12. Do not use abnormal batteries.
13. Pack the battery securely for transport.

Note: Use only with the included power supply, batteries, or a Shure-approved equivalent.

Storing Batteries

If batteries are to be stored for more than eight days, they should be placed into a temperature controlled storage area. Recommended battery storage temperature is 10 to 25°C (50 to 77°F).

Additional battery storage information is available at [shure.com/battery-storage](https://www.shure.com/battery-storage).



Important Product Regulatory Information

EMC conformance testing is based on the use of supplied and recommended cable types. The use of other cable types may degrade EMC performance.

Regulatory Information for Class B EMC Products

CE Notice

Hereby, Shure Incorporated declares that this product with CE Marking has been determined to be in compliance with European Union requirements.

The full text of the EU declaration of conformity is available at the following site: <https://www.shure.com/en-EU/support/declarations-of-conformity>.

UKCA Notice

Hereby, Shure Incorporated declares that this product with UKCA Marking has been determined to be in compliance with UK-CA requirements.

The full text of the UK declaration of conformity is available at the following site: <https://www.shure.com/en-GB/support/declarations-of-conformity>.

Cybersecurity STATEMENT OF COMPLIANCE

Product Type: Relevant connectable products defined as internet-connectable products or network-connectable products, in line with inter alia Product Security and Telecommunications Infrastructure Act 2022.

Manufacturer Statement: We, Shure Incorporated, certify and declare as manufacturer under our sole responsibility, that the above-mentioned product(s) conform(s) to the legislation as mentioned under Attachment 1 – to Cybersecurity Statement of Compliance listed here: <https://www.shure.com/en-GB/about-us/security>.

Information on how to report security issues: The latest version of Shure's Disclosure policy can be found at the following link: <https://www.shure.com/en-GB/about-us/security>

Security update periods: Shure provides support regarding hardware and software updates that continue the integral cyber security safety of Shure products up to 24 months after end of life (AEOL). For the full statement regarding Shure's product support policy, and information regarding products end of life status information can be found at the following link: <https://www.shure.com/en-GB/about-us/security>

Manufacturer:

Shure Incorporated 5800 Touhy Avenue
Niles, Illinois, 60714-4608 U.S.A. Website: www.Shure.com.

Technical documentation is kept at:

Shure Incorporated, Corporate Global Compliance Engineering Division

UK Importer/Representative:

Shure UK Limited
Unit 2, The IO Centre, Lea Road, Waltham Abbey, Essex, EN9 1AS, U.K.
Phone: +44 (0)1992 - 703058
Email: EMEAsupport@shure.de

On behalf of Manufacturer:

Chad Ayers
08 May 2025 Niles, Illinois
Senior Director, Global Compliance

FCC Notice

This equipment has been tested and found to comply with the limits for a Class B digital device pursuant to Part 15 of the FCC Rules. These limits are designed to provide reasonable protection against harmful interference when the equipment is operated in a residential installation. This equipment generates, uses, and can radiate radio frequency energy and, if not installed and used in accordance with the instructions, may cause harmful interference with radio communications. However, there is no guarantee that interference will not occur in a particular installation. If this equipment does cause harmful interference with radio or television reception, which can be determined by turning the equipment off and on, you are encouraged to try to correct the interference by one or more of the following measures:

- Reorient or relocate the antenna of the radio/television receiver.
- Increase the separation between this equipment and the radio/television receiver.
- Plug the equipment into a different outlet so that the equipment and the radio/television receiver are on different power mains branch circuits.
- Consult a representative of Shure or an experienced radio/television technician for additional suggestions.

This device complies with Part 15 of the FCC Rules. Operation is subject to the following two conditions:

1. This device may not cause harmful interference.
2. This device must accept any interference received, including interference that may cause undesired operation.

Notice: The FCC regulations provide that changes or modifications not expressly approved by Shure Incorporated could void your authority to operate this equipment.

For information regarding responsible party and other matters relating to FCC compliance, please contact Shure Incorporated, 5800 W. Touhy Avenue, Niles, Illinois 60714-4608 U.S.A. shure.com/contact

Canada, ISED Notice

Notice: The Industry Canada regulations provide that changes or modifications not expressly approved by Shure Inc. could void your authority to operate this equipment.

This Class B digital apparatus complies with Canadian ICES-003. Cet appareil numérique de la classe B est conforme à la norme NMB-003 du Canada.

Regulatory Information for Wireless Products

This equipment complies with FCC radiation exposure limits set forth for an uncontrolled environment. This equipment should be installed and operated with minimum distance 20 cm between the radiator & your body.

This equipment complies with FCC radiation exposure limits set forth for an uncontrolled environment. End user must follow the specific operating instructions for satisfying RF exposure compliance. This transmitter must not be co-located or operating in conjunction with any other antenna or transmitter.

The portable device is designed to meet the requirements for exposure to radio waves established by the Federal Communications Commission (USA). These requirements set a SAR limit of 1.6 W/kg averaged over one gram of tissue. The highest SAR value reported under this standard during product certification for use when properly worn on the body/head. This equipment should be installed and operated with minimum distance 0 cm between the radiator and your body/head.

Industry Canada (IC) Notices

This device contains licence-exempt transmitter(s)/receiver(s) that comply with Innovation, Science and Economic Development Canada's licence-exempt RSS(s). Operation is subject to the following two conditions:

1. This device may not cause interference.
2. This device must accept any interference, including interference that may cause undesired operation of the device.

L'émetteur/récepteur exempt de licence contenu dans le présent appareil est conforme aux CNR d'Innovation, Sciences et Développement économique Canada applicables aux appareils radio exempts de licence. L'exploitation est autorisée aux deux conditions suivantes :

1. L'appareil ne doit pas produire de brouillage;
2. L'appareil doit accepter tout brouillage radioélectrique subi, même si le brouillage est susceptible d'en compromettre le fonctionnement.

This equipment complies with ISED radiation exposure limits set forth for an uncontrolled environment. End user must follow the specific operating instructions for satisfying RF exposure compliance. This transmitter must not be co-located or operating in conjunction with any other antenna or transmitter. The antenna(s) must be installed such that a minimum separation distance of 20 cm is maintained between the radiator (antenna) and all persons at all times.

Cet équipement est conforme aux limites d'exposition aux rayonnements ISED établies pour un environnement non contrôlé. L'utilisateur final doit suivre les instructions spécifiques pour satisfaire les normes. Cet émetteur ne doit pas être co-implanté ou fonctionner en conjonction avec toute autre antenne ou transmetteur. La ou les antennes doivent être installées de telle façon qu'une distance de séparation minimum de 20 cm soit maintenue entre le radiateur (antenne) et toute personne à tout moment.

This equipment complies with ISED radiation exposure limits set forth for an uncontrolled environment. This equipment could be installed and operated with minimum distance 0 cm between the radiator and your body. End user must follow the specific operating instructions for satisfying RF exposure compliance. This transmitter must not be co-located or operating in conjunction with any other antenna or transmitter.

The portable device is designed to meet the requirements for exposure to radio waves established by the ISED. These requirements set a SAR limit of 1.6 W/kg averaged over one gram of tissue. The highest SAR value reported under this standard during product certification for use when properly worn on the body/head.

Cet équipement est conforme aux limites d'exposition aux rayonnements ISED établies pour un environnement non contrôlé. Cet équipement peut-être installé et utilisé avec une distance minimale de 0 cm entre le radiateur et votre corps. L'utilisateur final doit suivre les instructions spécifiques pour satisfaire les normes. Cet émetteur ne doit pas être co-implanté ou fonctionner en conjonction avec toute autre antenne ou transmetteur.

Le dispositif portable est conçu pour répondre aux exigences d'exposition aux ondes radio établie par le développement énergétique DURABLE. Ces exigences un SAR limite de 1,6 W/kg en moyenne pour un gramme de tissu. La valeur SAR la plus élevée signalée en vertu de cette norme lors de la certification de produit à utiliser lorsqu'il est correctement porté sur les corps/tête.

Additional Canadian information on RF exposure also can be found at the following Web address: <http://www.ic.gc.ca/eic/site/smt-gst.nsf/eng/sf08792.html>

ANATEL Notice

Este equipamento não tem direito à proteção contra interferência prejudicial e não pode causar interferência em sistemas devidamente autorizados. Para maiores informações, consulte o site da ANATEL – <http://www.anatel.gov.br>.

IFETEL Notice

La operación de este equipo está sujeta a las siguientes dos condiciones: (1) es posible que este equipo o dispositivo no cause interferencia perjudicial y (2) este equipo o dispositivo debe aceptar cualquier interferencia, incluyendo la que pueda causar su operación no deseada.

KCC Notice

해당 무선설비는 전파혼신 가능성이 있으므로 인명안전과 관련된 서비스는 할 수 없음.
이 기기는 전파법에 따라 과학기술정보통신부장관의 허가를 받고 운용하여야 합니다.

NBTC Notice

เครื่องโทรคมนาคมและอุปกรณ์นี้มีความสอดคล้องตามมาตรฐานหรือข้อกำหนดทางเทคนิคของ กสทช.

NCC Notice

Connection and use of this communications equipment is permitted by the Nigerian Communications Commission.

NCC Notice

低功率射頻器材技術規範

取得審驗證明之低功率射頻器材，非經核准，公司、商號或使用者均不得擅自變更頻率、加大功率或變更原設計之特性及功能。低功率射頻器材之使用不得影響飛航安全及干擾合法通信；經發現有干擾現象時，應立即停用，並改善至無干擾時方得繼續使用。前述合法通信，指依電信管理法規定作業之無線電通信。低功率射頻器材須忍受合法通信或工業、科學及醫療用電波輻射性電機設備之干擾。

614MHz-703MHz: 使用頻段供其他通訊業務使用時，器材應即停止使用

SRRC Notice

- (一) 本产品符合“微功率短距离无线电发射设备目录和技术要求”的具体条款和使用场景；
- (二) 不得擅自改变使用场景或使用条件、扩大发射频率范围、加大发射功率（包括额外加装射频功率放大器），不得擅自更改发射天线；
- (三) 不得对其他合法的无线电台（站）产生有害干扰，也不得提出免受有害干扰保护；
- (四) 应当承受辐射射频能量的工业、科学及医疗（ISM）应用设备的干扰或其他合法的无线电台（站）干扰；
- (五) 如对其他合法的无线电台（站）产生有害干扰时，应立即停止使用，并采取措施消除干扰后方可继续使用；
- (六) 在航空器内和依据法律法规、国家有关规定、标准划设的射电天文台、气象雷达站、卫星地球站（含测控、测距、接收、导航站）等军民用无线电台（站）、机场等的电磁环境保护区域内使用微功率设备，应当遵守电磁环境保护及相关行业主管部门的规定。

Canada Warning for Wireless

This device operates on a no-protection, no-interference basis. Should the user seek to obtain protection from other radio services operating in the same TV bands, a radio licence is required. For further details, consult Innovation, Science and Economic Development Canada's document Client Procedures Circular CPC-2-1-28, Voluntary Licensing of Licence-Exempt Low-Power Radio Apparatus in the TV Bands.

Ce dispositif fonctionne selon un régime de non-brouillage et de non-protection. Si l'utilisateur devait chercher à obtenir une certaine protection contre d'autres services radio fonctionnant dans les mêmes bandes de télévision, une licence radio serait requise. Pour en savoir plus, veuillez consulter la Circulaire des procédures concernant les clients CPC-2.1.28, Délivrance de licences sur une base volontaire pour les appareils radio de faible puissance exempts de licence et exploités dans les bandes de télévision d'Innovation, Sciences et Développement économique Canada.

ACMA Notice

WARNING: This device operates under an ACMA class license and must comply with all conditions of that license including operating frequencies.

MIC Notice

運用に際しての注意

この機器の使用周波数帯では、電子レンジ等の産業・科学・医療用機器のほか工場の製造ライン等で使用されている移動体識別用の構内無線局（免許を要する無線局）及び特定小電力無線局（免許を要しない無線局）並びにアマチュア無線局（免許を要する無線局）が運用されています。

1. この機器を使用する前に、近くで移動体識別用の構内無線局及び特定小電力無線局並びにアマチュア無線局が運用されていないことを確認して下さい。
2. 万一、この機器から移動体識別用の構内無線局に対して有害な電波干渉の事例が発生した場合には、速やかに使用周波数を変更するか又は電波の発射を停止した上、下記連絡先にご連絡頂き、混信回避のための処置等（例えば、パーティションの設置など）についてご相談して下さい。
3. その他、この機器から移動体識別用の特定小電力無線局あるいはアマチュア無線局に対して有害な電波干渉の事例が発生した場合など何かお困りのことが起きたときは、保証書に記載の販売代理店または購入店へお問い合わせください。代理店および販売店情報は Shure 日本語ウェブサイト <http://www.shure.co.jp> でもご覧いただけます。

現品表示記号について

2.4FH1

現品表示記号は、以下のことを表しています。この無線機器は 2.4GHz 帯の電波を使用し、変調方式は「FH-SS」方式、想定干渉距離は 10m です。2,400MHz～2,483.5MHz の全帯域を使用し、移動体識別装置の帯域を回避することはできません。

Environmental Regulatory Information

Waste Electrical and Electronic Equipment (WEEE) Directive



In the European Union and the United Kingdom, this label indicates that this product should not be disposed of with household waste. It should be deposited at an appropriate facility to enable recovery and recycling.

Registration, Evaluation, Authorization of Chemicals (REACH) Directive

REACH (Registration, Evaluation, Authorization of Chemicals) is the European Union (EU) and the United Kingdom (UK) chemical substances regulatory framework. Information on substances of very high concern contained in Shure products in a concentration above 0.1% weight over weight (w/w) is available upon request.

Recycling Information

Please consider the environment, electric products and packaging are part of regional recycling schemes and do not belong to regular household waste.

中国 RoHS

部件名称	有害物质									
	Pb	Cd	Hg	Cr(VI)	PBB	PBDE	DBP	BBP	DIBP	DEHP
电路模块	X	○	○	○	○	○	○	○	○	○
金属模块	X	○	○	○	○	○	○	○	○	○
线缆及其组件	X	○	○	○	○	○	○	○	○	○
电源适配器*	X	○	○	○	○	○	○	○	○	○
锂电池组*	X	○	○	○	○	○	○	○	○	○

注1: ○: 表示该有害物质在该部件所有均质材料中的含量均不超出电器电子产品有害物质限制使用国家标准要求。
X: 表示该有害物质至少在该部件某一均质材料中的含量超出电器电子产品有害物质限制使用国家标准要求。
注2: 本产品大部分的部件采用无害的环保材料制造, 含有有害物质的部件皆因全球技术发展水平的限制而无法实现有害物质的替代。
注3: 以上未列出的部分, 表明其有害物质含量均不超出电器电子产品有害物质限制使用国家标准要求
*表示如果包含部分

Battery Regulatory Information

EU and UK Battery Directive



In the European Union and the United Kingdom, this label indicates that the batteries in this product should be collected separately and not be disposed of with household waste. Substances in batteries can have a potential negative impact on health and environment and you have a role in recycling waste batteries thus contributing to the protection, preservation, and improvement of the quality of the environment. You should contact your local authority or retailer for details of the collection and recycling schemes available.

Certifications

Regulatory Model Number (RMN)

For regulatory identification purposes your product has been assigned a regulatory model number (RMN). This regulatory model number should not be confused with product number, as below.

RMN: SLXD4+/SLXD4D+	Product Numbers: SLXD4+ G54/SLXD4+ G57/SLXD4+ G60/SLXD4+ G64/SLXD4+ G65/SLXD4+ G66/SLXD4+ H58/SLXD4+ JB/SLXD4+ K55/SLXD4+ K60/SLXD4+ L60/SLXD4+ M55/SLXD4+ S50/SLXD4+ X51/SLXD4D+ G54/SLXD4D+ G57/SLXD4D+ G60/SLXD4D+ G64/SLXD4D+ G65/SLXD4D+ G66/SLXD4D+ H58/SLXD4D+ JB/SLXD4D+ K55/SLXD4D+ K60/SLXD4D+ L60/SLXD4D+ M55/SLXD4D+ S50/SLXD4D+ X51
RMN: SLXD1+	Product Numbers: SLXD1+ G54/SLXD1+ G57/SLXD1+ G60/SLXD1+ G64/SLXD1+ G65/SLXD1+ G66/SLXD1+ H58/SLXD1+ JB/SLXD1+ K55/SLXD1+ K60/SLXD1+ L60/SLXD1+ M55/SLXD1+ S50/SLXD1+ X51
RMN: SLXD2+	Product Numbers: SLXD2+ G54/SLXD2+ G57/SLXD2+ G60/SLXD2+ G64/SLXD2+ G65/SLXD2+ G66/SLXD2+ H58/SLXD2+ JB/SLXD2+ K55/SLXD2+ K60/SLXD2+ L60/SLXD2+ M55/SLXD2+ S50/SLXD2+ X51

RMN: SLXD3+**Product Numbers:** SLXD3+ G54/SLXD3+ G57/SLXD3+ G60/SLXD3+ G64/SLXD3+ G65/
SLXD3+ G66/SLXD3+ H58/SLXD3+ JB/SLXD3+ K55/SLXD3+ K60/SLXD3+ L60/SLXD3+
M55/SLXD3+ S50/ SLXD3+ X51

FCC / IC ID

CONTAINS FCC ID: DD4SH-BLE**CONTAINS IC:** 616A-SHBLE**FCC ID:** DD4SLXD1EG57, DD4SLXD2EG57, DD4SLXD3EG57**IC:** 616A-SLXD1EG57, 616A-SLXD2EG57, 616A-SLXD3EG57

Energy Efficiency

External Power Supply meets:

1. The U.S. Energy Conservation Standards specified in the Code of Federal Regulations at 10 CFR 430 32(w).
2. EU COMMISSION REGULATION (EU) 2019/1782 of 1 October 2019: Ecodesign requirements for External Power Supply.
3. Australian Standard requirements of AS/NZS 4665.1:2005 and AS/NZS 4665.2:2005.

Battery Charger System meets:

1. The U.S. Energy Conservation Standards specified in the Code of Federal Regulations at 10 CFR 430 32(z)
2. Canada NRCan standard: CAN/CSA-C381.2